

Eco4847P

---

# Installation and Operation Manual

---

Your complete installation guide  
for Eco4847P batteries

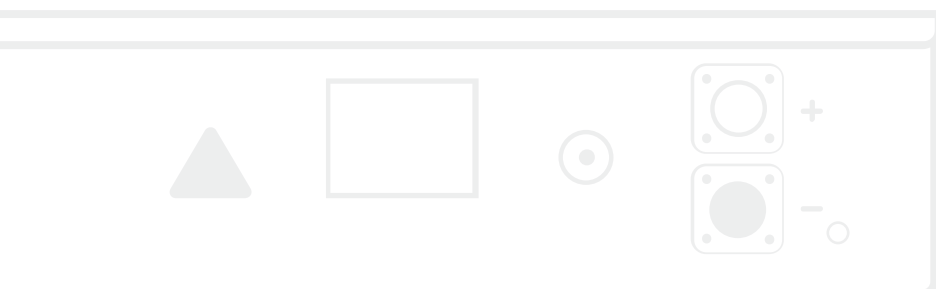

# CONTENTS

<b>1. Introduction</b>	<b>3</b>
<b>2. Glossary</b>	<b>3</b>
<b>3. Safety</b>	<b>4</b>
3.1. Transportation	4
3.2. Basic Safety	5
3.3. Handling	5
3.4. Storage of the Battery	5
3.5. Life Support	6
3.6. Damaged Battery*	6
3.7. Fire*	6
3.8. Qualified Person (Installer)	6
3.9. Wet Battery	6
<b>4. Product Information</b>	<b>7</b>
4.1. Introduction	7
4.2. Front Panel	7
4.3. Inclusions	7
4.4. Eco4847P Specifications	8
4.5. Charging and Discharging	9
4.5.1. Charging/Discharging Curves	9
4.5.2. State of Charge vs Discharge Voltage	10
4.5.3. Over Discharged Battery	10
4.6. DC Circuit Breaker Characteristics	10
<b>5. Installation</b>	<b>11</b>
5.1. Location and Environment	11
5.1.1. Extreme Humidity Climates	11
5.2. Battery Installation	12
5.2.1. Custom Cabinets	12
5.2.2. Battery Orientation for Stationary Applications	12
5.2.3. Battery Transportation within a Preassembled BESS	12
5.2.4. Battery Installation in Motorhomes, RV's, Trailers, Vehicles, Trucks, Buses or Similar	13
5.2.5. Battery Rack Ears	13
5.3. Battery Connections	13
5.3.1. Main DC Connections	14
5.3.2. Connecting Amphenols to Battery Terminals	14
5.3.3. Case Earthing	14
5.3.4. Battery Alarm Output	15
<b>6. Battery Operation</b>	<b>17</b>
6.1. Status LED	17
6.2. DC Circuit Breaker	17
6.2.1. Battery System Startup	18
6.2.2. Battery System Shutdown	18
6.3. Charging and Discharging	19
6.3.1. Full charge Upon First Installation	19
6.3.2. Battery String Balancing	19
6.3.3. Primary Charging Source	20
6.3.4. Secondary Charging Source	20
6.3.5. Primary Charging Source with Secondary Charging Source Example	20
6.3.6. Power Conversion Equipment (PCE) Settings	20
6.3.7. Compatibility with PWM charger	20
6.4. Calibration to 100%	20
6.5. SoC (State of Charge) Drift	20
<b>7. Troubleshooting</b>	<b>22</b>
7.1. Under Voltage Battery Recovery	23
7.1.1. Under Voltage Shutdown	23
7.1.2. BMS Threshold Under Voltage Shutdown	23
7.1.3. Under Voltage Shutdown Recovery	23
7.1.4. Critically Under Voltage Shutdown	23

7.1.5. Critically Under Voltage Shutdown Recovery .....	23
7.1.6. Extreme Cold.....	24
<b>8. Maintenance .....</b>	<b>24</b>
<b>9. Upgrading Battery Capacity .....</b>	<b>24</b>
<b>10. Capacity Testing the Battery .....</b>	<b>25</b>
<b>11. Compatible Grid-Connect Hybrid Inverters .....</b>	<b>25</b>
<b>12. End of Life .....</b>	<b>26</b>
<b>13. Warranty .....</b>	<b>26</b>

# 1. INTRODUCTION

PowerPlus Energy designs and manufactures Lithium Ferro Phosphate (LiFePO<sub>4</sub> or LFP) batteries in Australia, to operate in some of the world's harshest operating environments. The Eco4847P battery is a simple, safe, flexible, and reliable energy storage component that is designed to be easily integrated with most inverter and charger combinations.

It can work well as a UPS battery or as a cyclical energy storage reserve for solar, wind and other energy sources. It is designed to be connected to most DC and AC charging devices and it performs very well, with virtually no maintenance, in both on-grid and off-grid system designs in single-, two- and three-phase BESS (Battery Energy Storage System) applications.

This document outlines the technical capabilities of the PowerPlus Energy Eco4847P battery and offers installers useful information and tips to safely integrate this product into BESS systems.

As this product stores very large amounts of electrical energy and can release that energy in a very short time, it must be treated with care both during installation and operation.

When the Eco4847P has been installed as intended, it will deliver its intended and rated electrical performance over its long 10-year limited warranty life (See Warranty Statement).

# 2. GLOSSARY

<b>BESS</b>	Battery Energy Storage System
<b>BMS</b>	Battery Management System
<b>BS</b>	Battery System
<b>LED</b>	Light Emitting Diode
<b>LFP</b>	Lithium Ferro Phosphate (LiFePO <sub>4</sub> )
<b>PCE</b>	Power Control (or Conversion) Electronics
<b>RJ45</b>	An 8-way modular connector specification for connectors and cabling
<b>SDS</b>	Safety Data Sheet
<b>SWMS</b>	Safe Work Method Statement



Read the manual before installation and operation



Pay attention to the potential dangers of using the battery

## 3. SAFETY



### IMPORTANT

Installers/users are responsible for familiarising themselves with this manual and product SDS before starting.



### IMPORTANT

Installation must be carried out by a suitably qualified and experienced person who can specify the correct cables, DC bus arrangement and additional external circuit protection. It is crucial that this battery is installed in accordance with all necessary local and international standards.

Eco4847P battery is a member of the Eco series of batteries and has a nominal operating voltage of 48V.

This battery uses high grade cylindrical Lithium Ferro Phosphate (LiFePO<sub>4</sub> or LFP) cells which are robust and reliable when operated in higher ambient temperatures. The battery is designed to have a long service life when installed and operated within the specifications contained in this document.

The battery contains no heavy metals, and most components are recyclable (by licensed recycling companies).

A pair of high quality, high current Amphenol SurLok DC connections enable users to install the Eco4847P safely and rapidly into a variety of energy storage configurations.

To meet stringent international battery safety standards, each battery is fitted with a 2-pole, non-polarised K-Curve circuit breaker that also doubles as a point of isolation. There is a blue status indicator light that assists installers and users with helpful diagnostic information. There is also a volt-free alarm contact that allows the battery to be monitored by external devices and control systems.

Each Eco4847P battery is also fitted with an internal BMS that provides protection against over-charging and excessive discharging. The BMS will shut down the battery when it exceeds its over-current limit or experiences an external short circuit. The battery will also protect itself when exposed to over and under-temperature conditions. For a long and reliable service life, the BMS carefully manages cell-string balancing during charging.

### 3.1. TRANSPORTATION

Although PowerPlus Energy's Eco4847P battery is classed as a Dangerous Goods (DG) Class 9 UN3480 product, this battery carries a UN38.3 transport safety certificate and is therefore safe for all types of transport methods.

The battery is shipped with the terminals capped to prevent electrical short circuit and contact with metallic objects during transportation. The batteries leave our warehouse in a partially discharged state to comply with international transport regulations including IATA. Contact PowerPlus Energy for specific declarations as required.

Batteries, where possible, should be shipped in the original manufacturer's packaging, positioned horizontally, and secured to a pallet. The batteries are not designed to be shipped in a vertical orientation, and there should not be more than 6 batteries in a stack when being transported.

### 3.2. BASIC SAFETY



#### WARNING

Serious injury or damage to property may result from careless handling of the Eco4847P battery.

The following precautions should be observed:

- The battery must not be exposed to temperatures above or below the temperature ratings specified in [Section 4.4 \(Operating Temperature Range\)](#).
- The battery must not be installed in direct weather including sunlight, rain and saline or polluted environments.
- The battery must not be exposed to strong impacts and/or vibrations.
- The battery must not be crushed or punctured.
- The battery's connectors should not touch conductive surfaces unless intended to do so.
- The battery does not contain maintainable or user serviceable components and must not be disassembled or opened for repair.
- The battery must be kept dry at all times and must not be exposed to water or other liquids. Do not touch the battery if it appears to be damp or wet.
- The battery should be kept away from animals and children.
- The battery must not be stepped on or subjected to any strong force.
- The battery is intended to be lifted by 2 persons during installation and handling.
- The battery should not be disposed of with household waste. Refer to [Section 12](#) for end of life details.

### 3.3. HANDLING

- Handle the battery with care when installing or transporting.
- The battery is heavy and proper lifting techniques or equipment should be applied.
- Do not use the battery if it appears damaged or broken.
- Do not use chemicals to clean the battery.
- Do not touch the DC terminals of the battery.
- Do not touch the DC busbar.

### 3.4. STORAGE OF THE BATTERY

- The battery must be stored horizontally, and there must be no more than 6 batteries stacked on top of each other without additional mechanical support.
- The battery must be kept in a dry environment away from heat and moisture.
- The battery must be stored away from incompatible substances, like liquid, chemical materials.
- The battery should be stored between 0 to 35°C, however, temperatures close to 25°C should be considered for long term storage.
- After 6 months of storage the battery will need a periodic recharge.
- Any issues with charging after long term storage should be discussed with PowerPlus Energy.

### **3.5. LIFE SUPPORT**

PowerPlus batteries should not be used in critical medical or life support applications where failure of the Eco4847P batteries can reasonably be expected to cause failure of the life support equipment or effect operation of such equipment.

### **3.6. DAMAGED BATTERY\***

A damaged battery should not be used and should be returned to PowerPlus Energy or disposed of via a recycling facility. Leaking electrolyte can cause breathing difficulties, skin irritation or chemical burns, so contact should be avoided.

### **3.7. FIRE\***

- Evacuate the area and call emergency services.
- Some toxic gases may be produced if the battery catches fire.
- The battery needs to be rapidly cooled to prevent any heat or fire spreading.

### **3.8. QUALIFIED PERSON (INSTALLER)**

The tasks outlined in this manual regarding installation should be carried out by a suitably qualified and skilled person who should:

- Have a thorough understanding of operations, design, and installation principles of battery energy storage systems.
- Have a thorough understanding of all dangers and risks associated with installing and using electrical devices.
- Hold all local, state and country base qualifications to carry out such work.
- Adhere to all safety and installations requirements within this manual.

### **3.9. WET BATTERY**

Do not attempt to access the battery if it is wet or submerged in water. Seek technical assistance from PowerPlus Energy or your distributor.

*\*Refer to product [SDS document](#) for more details, also available on the PowerPlus Energy website.*

## 4. PRODUCT INFORMATION

### 4.1. INTRODUCTION

The PowerPlus Energy Eco4847P is a 'self-managed' battery in that it doesn't require communication with external Power Control Electronics (PCE) to operate.

Each battery module has an internal BMS which is designed to protect it from adverse and incorrect operating conditions such as:

- Over-charging and excessive discharging.
- Over-temperature and under-temperature.
- Over-current and short-circuit.



### IMPORTANT

BMS provides limited protection and operating the battery outside the recommended parameters ([Section 4.4](#)) may void the limited warranty.

### 4.2. FRONT PANEL

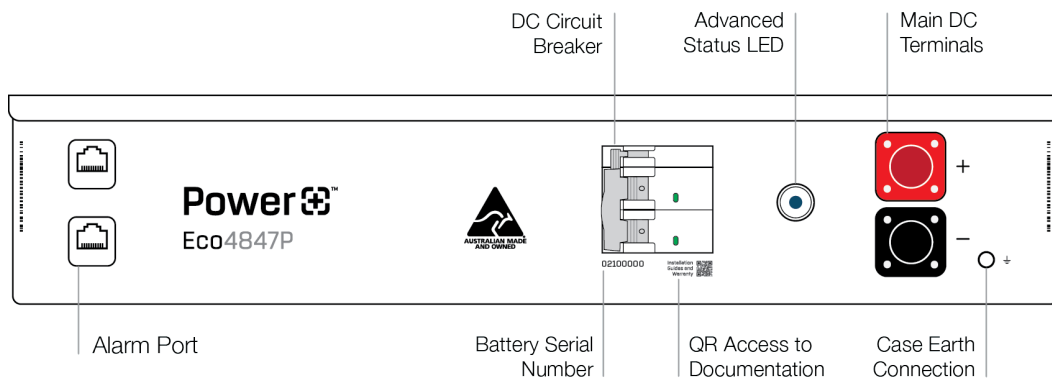

### 4.3. INCLUSIONS

Each battery comes supplied in a cardboard box that should be retained in case there is a need to return the battery to PowerPlus Energy.

**Note:** Battery connectors are supplied separately from your point of purchase on demand as pre-made PowerPlus cabinets are supplied with these pre-wired. All other accessories are sold separately.

	DC Connector
Positive DC connection	1 x SLPPA16BSR
Negative DC Connection	1 x SLPPA16BSB
25mm to 16mm Reducer	x2



#### 4.4. Eco4847P SPECIFICATIONS

Nominal DC Voltage <sup>1</sup>	51.2V
Operational Voltage Window <sup>1</sup>	40V to 58.4V
Nominal Capacity	4.7kWh / 92Ah
Usable Capacity <sup>2</sup>	4.7kWh (92Ah)
Recommended Usable Capacity @ 80% Depth of Discharge	3.76kWh
Depth of Discharge	Up to 100%
Recommended Depth of Discharge	80% or less
Maximum Continuous Discharge C-Rate	0.68C
Maximum Continuous Discharge Current	63A (3.22kW)
Maximum Discharge Current (Limited by K-Curve Circuit Breaker)	63A (3.22kW)
Maximum Charge Current	63A (3.22kW)
Nominal Charge Current	46A (2.35kW)
Battery Fault Current	250A
Circuit Breaker (K-Curve)	2-Pole 63A 360VDC
Lithium Composition	Lithium Ferro Phosphate (LiFeP04 or LFP)
Operating Temperature Range	Charge: 4° to 51°C / Discharge -6° to 56°C
Operating Humidity	Up to 85% – non-condensing
BMS Under/Over-Volt Module Level Protection <sup>1</sup>	40V / 58.4V
BMS Under/Over-Volt Cell Level Protection	2.5V / 3.65V
BMS Over/Under-Temp Cut Off	Charge: 53°C / 2°C Discharge: 58°C / -8°C
Self Discharge	<14% Per Annum
Altitude	< 2000m (seek advice from PowerPlus Energy above 2000m)
Battery Mounting Options	Standard 19" Rack Mount / Horizontal / Vertical
Terminal Connections	Amphenol Surlok 100A non-keyed
IP Rating	IP40
Efficiency	>96%
Cooling	Natural Convection
Parallel Connection	Unlimited – Refer to Manufacturer
Series Connection	Not Permitted
Alarm Output	Normally Closed. Volt-free, 100mA 60V Max
Communications	Alarm Output
Module Weight	43kg
Battery Dimensions	635mm D x 443mm W x 88mm H
Certifications	<b>Battery:</b> IEC 61000-6-3:2020 ( <i>Pending</i> ), IEC 62368-1:2023 ( <i>Pending</i> ) IEC 62619:2022 ( <i>Pending</i> ), UN38.3 ( <i>Pending</i> ) <b>Battery Cells:</b> IEC 62619:2022, UL1642
Warranty	10 Years (conditions apply)

Specifications correct at time of publication and subject to change. Refer to website for latest information.  
 1. Voltages are specified at the battery terminals 2. The usable capacity is measured under specific conditions of 0.25C

*Table 1 (Specifications)*

## 4.5. CHARGING AND DISCHARGING

### 4.5.1. CHARGING/DISCHARGING CURVES

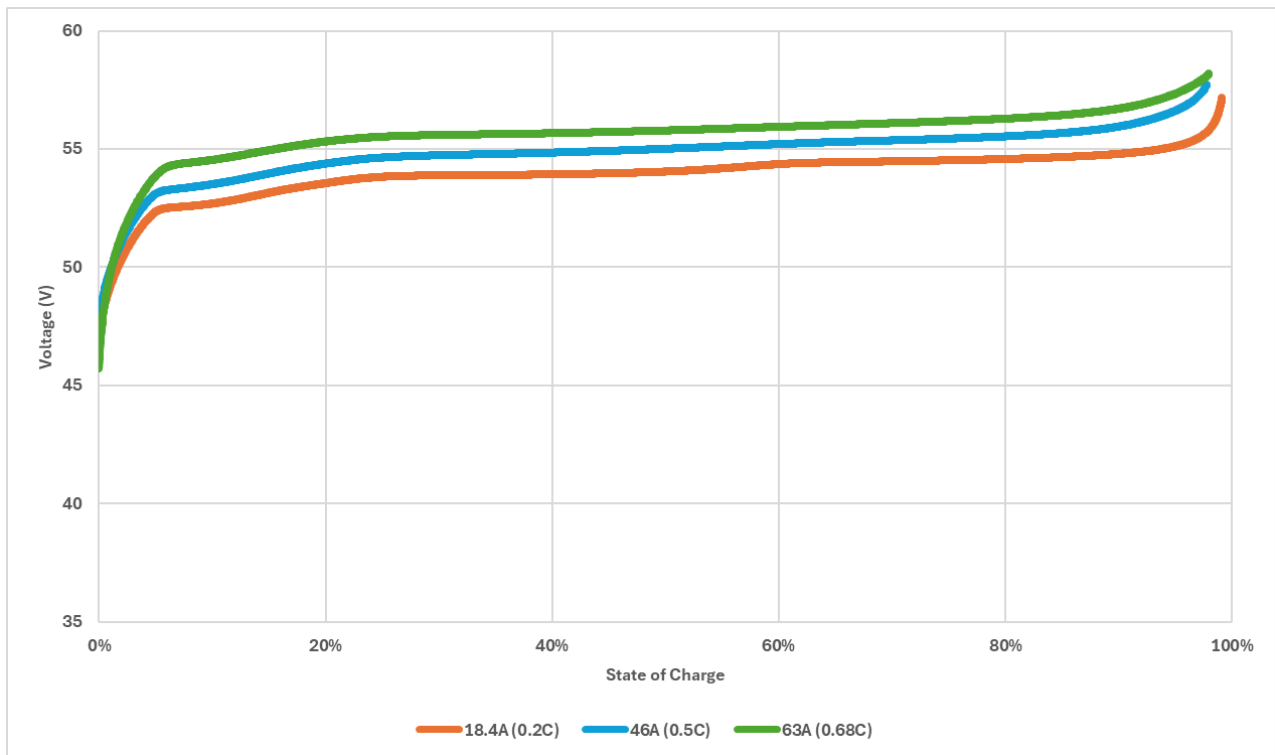

Figure 1 (Voltage/Current Curve during Charging)

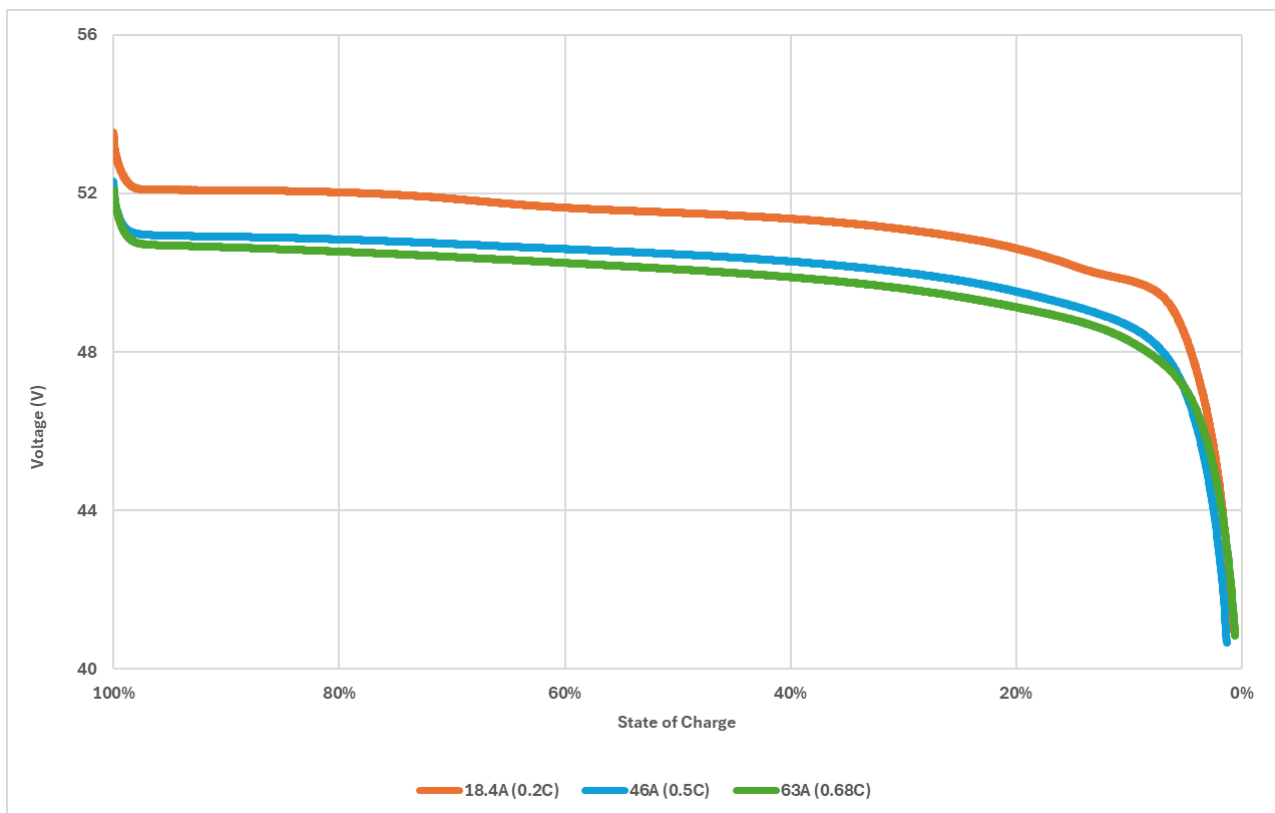

Figure 2 (Voltage/Current Curve during Discharging)

### 4.5.2. STATE OF CHARGE VS DISCHARGE VOLTAGE

The table below can be used as a guide for referencing voltage against energy in the battery. The figures in the table are taken at 25°C and with a 0.5C load applied.

100%	>53V	50%	50.46V
90%	50.91V	40%	50.28V
80%	50.84V	30%	50.00V
70%	50.72V	20%	49.52V
60%	50.59V	10%	48.65V
		0%	40.00V

### 4.5.3. OVER DISCHARGED BATTERY

In the event the low voltage protection circuit has operated to protect the battery from excessive discharge, it is important that the battery is charged to 100% within 7 days. Leaving the battery in a discharged state can cause irreversible damage to the battery or battery capacity.

### 4.6. DC CIRCUIT BREAKER CHARACTERISTICS

The integrated non-polarised DC Circuit Breaker is dual pole and a K curve type. The table below outlines the trip times based on current.

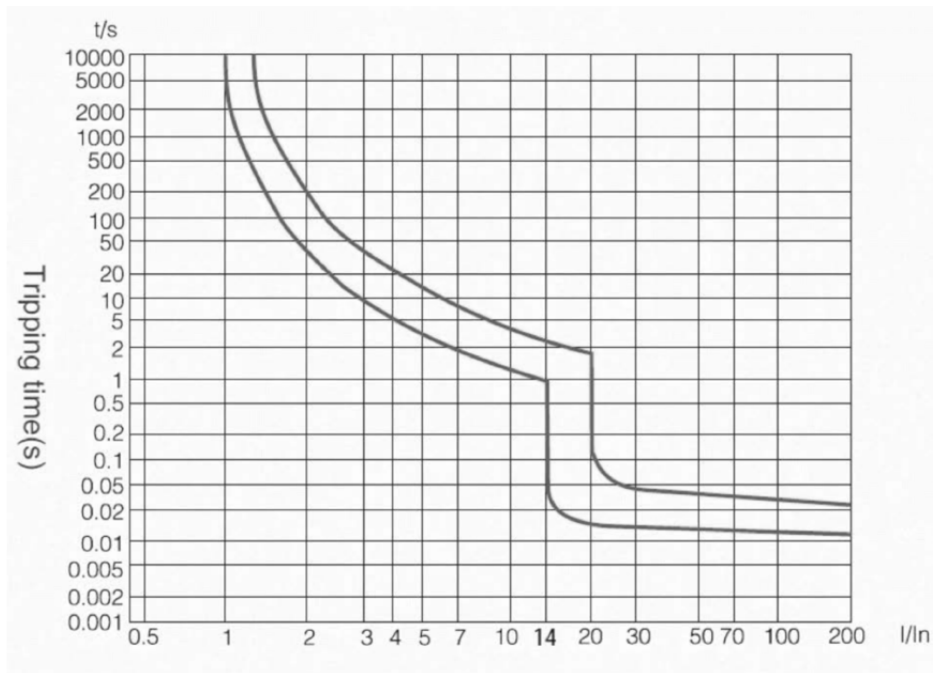

Figure 3 (Characteristic K Graph)

## 5. INSTALLATION

This section of the document provides important information and guidance to installers to ensure a safe and trouble-free installation process. Installation should be carefully considered, and all aspects of the specifications should be understood to determine a suitable location and way of installing the battery.

### 5.1. LOCATION AND ENVIRONMENT

The location of the battery should be in accordance with the IP rating specified in [Section 4.4 \(IP Rating\)](#) and operating temperature range specified in [Section 4.4 \(Operating Temperature Range\)](#).

The Eco4847P battery is designed to be installed in PowerPlus Energy rack mount and slimline cabinets, 19" data racks, or an electrical or custom cabinet of your choice. The external rack assembly or electrical enclosure is considered outside the scope of the battery product certification. If the battery is to be installed outdoors, a suitable enclosure with IP54 (or greater) rating should be used.

The location of the battery should meet the below conditions:

- Due to the risk of short circuits and rapid metal corrosion, the battery should not be installed where direct contact of salt air may be possible. If salt air is unavoidable, appropriate air filtration must be employed to keep the battery free of salt deposits. It is highly recommended that the battery should be installed in an indoors environment, or inside an IP66 or greater enclosure.
- The floor is level and free from obstructions.
- There are no explosive or flammable materials nearby.
- The temperature and humidity should remain as constant as possible.
- The area is of a clean environment with minimal dust.
- The area or enclosure is insect and vermin proof.
- The batteries and battery cabinets/housings are not exposed to direct sunlight.

#### 5.1.1. EXTREME HUMIDITY CLIMATES

When PowerPlus Energy's Eco4847P batteries are being installed in elevated humidity conditions, extra precautions should be taken:

- A humidity control agent (i.e., chemical which absorbs humidity) may be required inside the enclosure, with controlled airflow to expel moist air.
- The battery system could also be installed in a humidity- and climate-controlled room (example, reverse cycle air-conditioner cooled).
- The temperature of the cabinet should be always held at a temperature above dew point.



#### WARNING

If the battery is not stored or operated within the recommended temperature range specified in [Section 4.4](#), the BMS may halt the operation of the battery as a protective measure. It is important to note that if the battery is subjected to extreme temperatures frequently, there may be a negative impact to its long-term performance and reduce its longevity.



#### NOTE

Battery will exhibit optimal performance and lifespan if it is operated within its ideal temperature range.

## 5.2. BATTERY INSTALLATION

PowerPlus Energy highly recommends their [Rack Series](#) or [Slimline Series](#), indoor and outdoor cabinets for containing the batteries in a system installation. Full specification details are available on the PowerPlus Energy website.

However, this section provides instructions which should be followed when creating a custom enclosure or system for containing the batteries.

### 5.2.1. CUSTOM CABINETS

The battery has been designed to fit into a standard 800mm deep 19-inch equipment rack.

If you are planning to design and assemble your own battery enclosure, please carefully consider the following suggestions and recommendations:

- If the battery is installed into enclosures without rails, please ensure that they are securely seated to prevent accidental damage or tampering.
- If a custom enclosure or mounting method is used, please ensure the batteries are not stacked more than 6 high unless battery support rails are used to distribute weight.
- Please ensure there is adequate air flow around the battery stack within the cabinet. Except for the top and bottom surfaces of the stack, a clearance of at least 25mm is required around the stack (4 sides of the stack).
- Please ensure the selected IP rating is correct as per your location selection.
- All interconnecting battery cables for parallel connection shall be the same length and cable size.
- A busbar is recommended for connection of all parallel battery connections.
- Please follow PCE instructions for fuse, cable, and connection requirements. These will vary depending on brand and product selected.

### 5.2.2. BATTERY ORIENTATION FOR STATIONARY APPLICATIONS

In stationary applications, other than resting the battery on its front face or resting it on its lid (upside down), the battery can be mounted in any of the other four possible orientations:

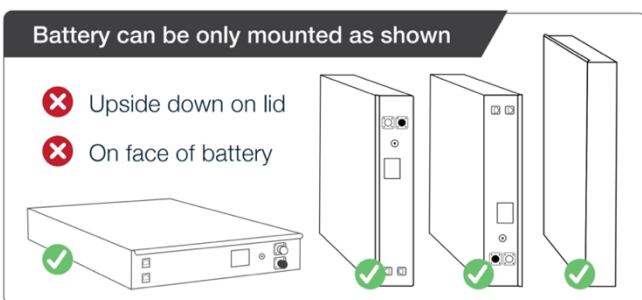

### 5.2.3. BATTERY TRANSPORTATION WITHIN A PREASSEMBLED BESS

If the battery is to be pre-installed into a BESS in which it is shipped, the following guidance must be followed:

- The battery should be shipped horizontally and secured in place to limit movement.
- If the battery is to be subjected to prolonged vibrations during transportation, a sufficient non-flammable shock mount system (like high density foam or similar) should be installed within the BESS under the battery.

If the guidance above cannot be followed, the battery must be removed from the BESS and shipped in the original manufacturer's packaging.

### 5.2.4. BATTERY INSTALLATION IN MOTORHOMES, RV'S, TRAILERS, VEHICLES, TRUCKS, BUSES OR SIMILAR

- The battery should be installed horizontally (with the lid upwards) and secured in place to limit movement.
- The battery should be positioned in a non-flammable section and be vented to the outside, easily accessible, and removable from outside of the vehicle.
- A sufficient non-flammable shock mount system (like high density foam or similar) should be installed under each battery.
- Batteries can be stacked no more than four high.

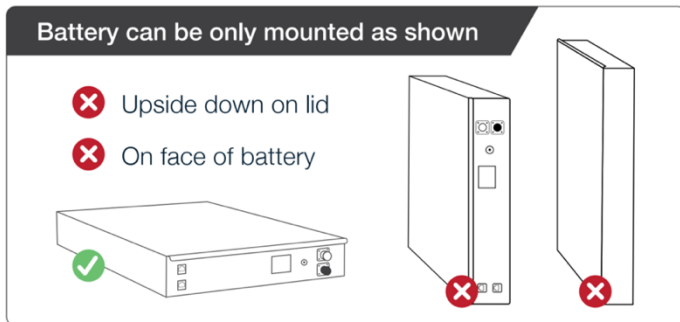

### 5.2.5. BATTERY RACK EARS

Battery has three mounting points for rack ears on the front of each side of the battery for locking the battery into the rack. Rack ears can be purchased separately from PowerPlus Energy. They are installed as follows:

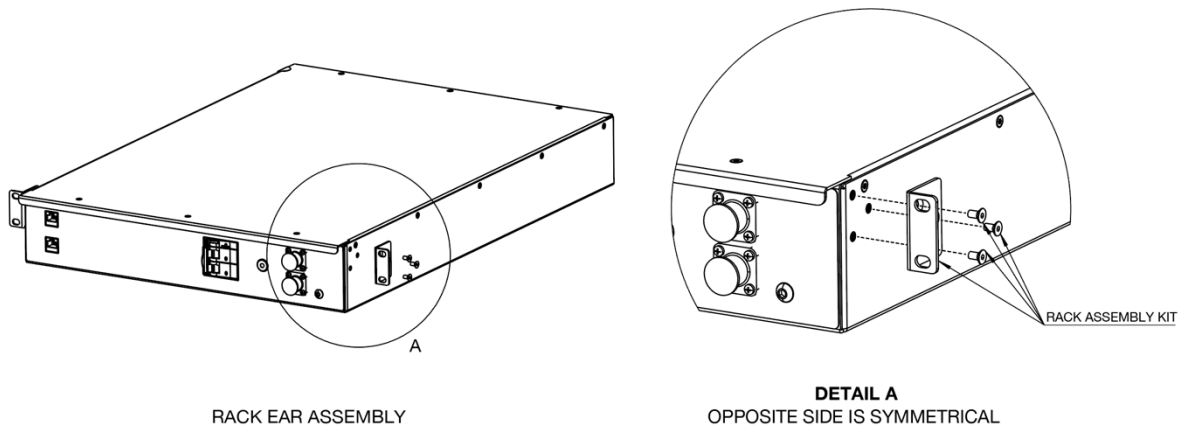

### 5.3. BATTERY CONNECTIONS

Each battery has a positive and negative Amphenol SurLok (non-keyed) connector for easy snap-on connection. Cables and mating connectors are available from any PowerPlus Energy place of purchase.



#### NOTE

If multiple batteries are being used in parallel, the battery cables shall all be of the same length to retain equal impedance of each battery and cable set.

### 5.3.1. MAIN DC CONNECTIONS

The battery comes fitted with Amphenol Surlok connectors (non-keyed) connectors. The table below outlines the battery connections, and the mating cable connectors required. Each battery when ordered separately (without a cabinet) will come supplied with connectors.

Each Amphenol SurLok connector supplied by PowerPlus Energy can adequately seat 25mm single insulated or 16mm double insulated cable. A 16mm reducing sleeve is provided. Crimping of SurLok to the stripped end of the cable is performed using a standard 25mm hex crimp tool.

Before connecting the DC cable to the battery, you will need to remove the safety insulating cap on the battery DC connectors and dispose of appropriately.

Positive connection	SLPPA16BSR
Negative Connection	SLPPA16BSB



#### WARNING

Do not connect the main DC cable with reversed polarity. It will cause severe damage to the battery.

### 5.3.2. CONNECTING AMPHENOLS TO BATTERY TERMINALS

When connecting the Amphenol SurLok plug into the socket, the plug must be pushed until an audible click is heard. This indicates the plug has locked onto the battery terminal.

To remove the plug, press in the button on the underside of the plug before pulling the plug out. This releases the locking mechanism.

Failure to release the locking mechanism before trying to remove the connector may result in damage to the SurLok plug and/or battery.

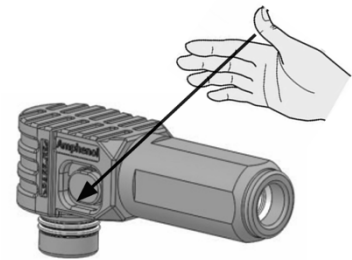

Figure 4 (Press button to release lock)



#### WARNING

Ensure all loads and charging sources are removed from the battery before disconnecting the battery connectors.

### 5.3.3. CASE EARTHING

The Eco4847P battery case is designed to be electrically floating and isolated from all internal battery connections and in most installations will not require earthing. However, should your application require the case to be grounded a 5mm M6 bolt should be used and is supplied with the battery.

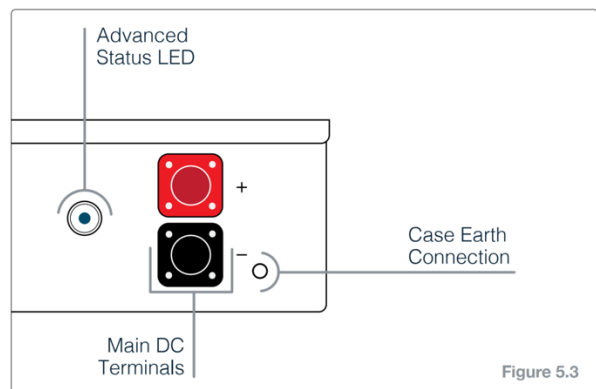

Figure 5.3

### 5.3.4. BATTERY ALARM OUTPUT

The battery is equipped with a Battery Alarm Output that notifies an external system when the BMS or the DC Circuit Breaker has tripped. The BMS trip will self-reset in most circumstances once the fault has been resolved or removed, however if the battery's DC Circuit Breaker has tripped, it will need manual intervention. See [Section 7](#) for further information.

The Battery Alarm Output is presented on the two RJ45 connectors on the front panel of the battery. The Battery Alarm Output is present on pins 5 and 6 of the RJ45 connectors as a pair of volt-free contacts. These volt-free contacts can be used to signal to an external PLC or alarm circuit.

The Battery Alarm Output is normally closed when energised by the battery (battery is ON and LED illuminated). When the BMS or DC Circuit Breaker trips, the battery turns OFF (circuit breaker or BMS trip and LED off) and the contacts will open.

The alarm outputs are designed to be daisy chained using a standard data or patch lead (available for purchase from PowerPlus if need), connecting the bottom RJ45 of a battery to the top RJ45 of the battery immediately below, and so on. The battery at the end of the chain (generally the bottom battery) will need to have pins 5 and 6 bridged on the bottom RJ45 terminals using a bridging connector (P/N COMLBA). The top connector on the first battery in the chain (generally the top battery) can be connected to an appropriate alarming circuit using one of our battery comms cables.

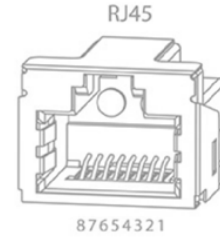

RJ45 pin colour coding acc. to EIA / TIA 568 A and B

	EIA/TIA 568 A	PIN RJ45	EIA/TIA 568 B	
pair 3	white	1	white	pair 2
	green	2	orange	
	green	3	orange	
	white	4	white	pair 1
pair 1	blue	5	blue	pair 3
	white	6	white	
	blue	7	green	
pair 2	orange	8	white	pair 4
	orange		brown	
pair 4	white		brown	
	brown		brown	

1	Unused
2	Unused
3	Unused
4	Unused
5	Alarm
6	Alarm
7	Unused
8	Unused

Description	Part Number
A range of cables to connect the battery alarm contacts are available for purchase.	
Battery Bridge connector	COMLBA
Battery daisy chain connector lead (30cm)	COM003A
Battery Comms Cable (2m)	COM020A
Battery Comms Cable (5m)	COM050A
Battery Comms Cable (10m)	COM100A
Battery Comms Cable (15m)	COM150A



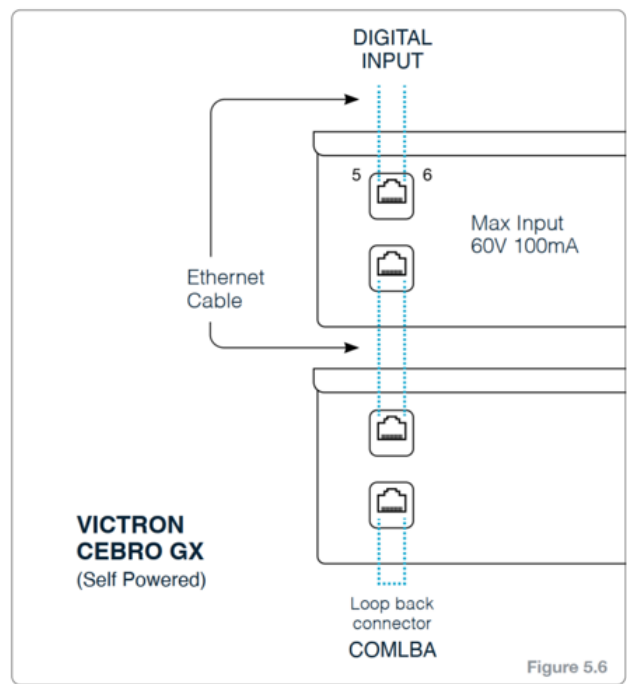
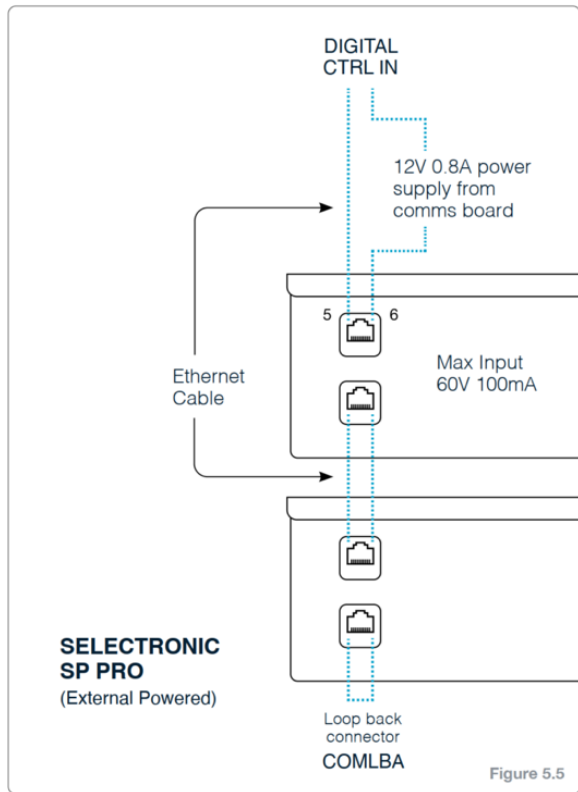

Figure 5 (Specific examples of how to use alarm contacts)

## 6. BATTERY OPERATION

Now that you have installed the batteries you are almost ready to energise the system.

First you should check your installation to ensure the below:

- Check polarity of all battery connections to be correct.
- Check that there is no damage to cables and all connections are tightened to correct torque specifications.
- Check that all system breakers are in the off position.
- Check for adequate air flow as per your installation requirements.
- Check for local installation compliance if applicable.

Starting up the battery system should be done in conjunction with the PCE manufacturer's recommendations as well as this manual and any local or government safety requirements.

Each battery in the system is powered up separately by turning the double pole breaker to the ON position. Once powered up, voltage will be present at the DC terminals and the Main Status LED light will glow blue. The BMS takes a few seconds to power up and the status indicator to illuminate.

### 6.1. STATUS LED

The Status LED indicator is used to provide a visual indication of the operation and state of the battery.

Status	Operational State
ON	Battery is ON and allowing charge and discharge.
OFF	Battery circuit breaker is in the OFF position.
OFF	Battery circuit breaker is in the ON position and battery BMS is in protection mode: Charge and discharge will not be permitted until battery is recovered. See detailed information listed in <a href="#">Section 7</a> .
FLASH	Battery is in protection mode. See detailed information listed in <a href="#">Section 7</a>



#### IMPORTANT

If a fault occurs, the battery will enter its protection mode, and the Status LED will start to flash periodically to indicate the fault. The alert codes in [Section 7](#) can help diagnose and troubleshoot problems quickly and efficiently

### 6.2. DC CIRCUIT BREAKER

Each battery has an integrated DC circuit breaker.

- Firstly, it is the ON/OFF switch for the battery.
- Secondly, it protects the battery in the event of an internal battery fault.
- Finally, it is also used to safely and easily isolate the battery from the DC bus inside the rack or the Battery Energy Storage System (BESS).



#### IMPORTANT

If the power system has been shut down or charging source has been removed, the battery should have its circuit breaker switched to the OFF position within 7 days.

### 6.2.1. BATTERY SYSTEM STARTUP

The battery system should be started following the startup procedure supplied with the system.

The Eco4847P battery does not provide an output voltage until it is turned on. In most cases powering on the battery will be one of the first steps of starting your power system.

1. Locate and ensure your main system isolation point is OFF.
2. Check all battery connections are tight and secured.
3. Systematically turn each battery DC circuit breaker to the ON position (switch to the right when looking at the front face of the battery).
4. Status LED will illuminate indicating voltage is present at the battery terminals.
5. Turn on main system isolation.
6. Turn on PCE.

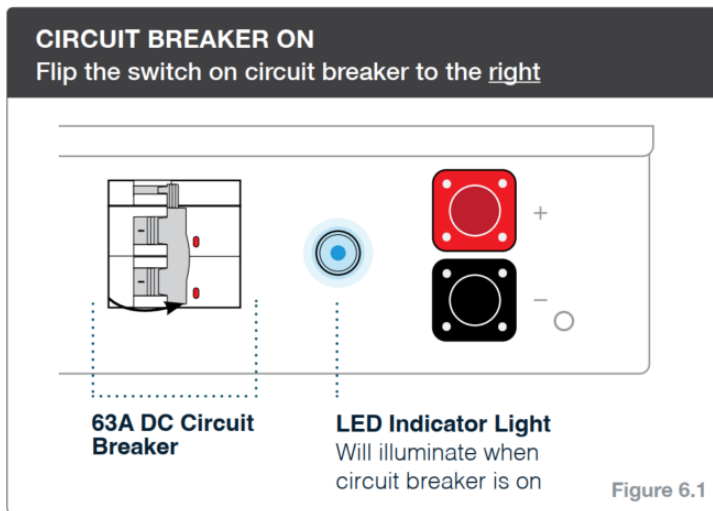

### 6.2.2. BATTERY SYSTEM SHUTDOWN

Use the following steps to shut down the battery system:

1. Turn off the PCE.
2. Turn off main system isolation.
3. Turn off each battery by turning its DC circuit breaker to the OFF position.
4. Ensure the Status LED on all batteries in the rack are no longer illuminated.

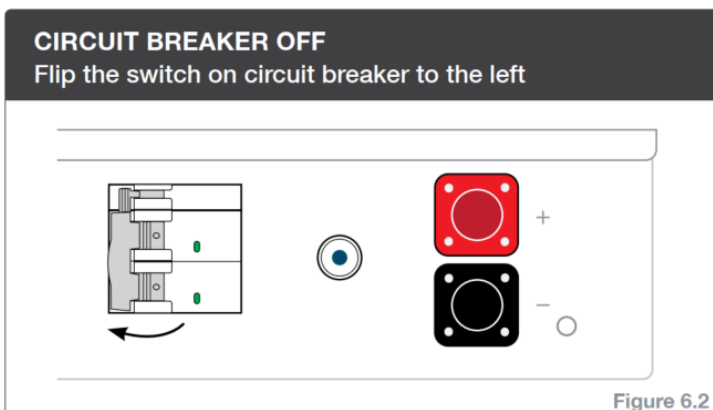

### 6.3. CHARGING AND DISCHARGING

As outlined in [Section 4.4 \(Operating Temperature Range\)](#), whilst being charged, the battery temperature should be between 4° and 51°C. Whilst being discharged the battery temperature should be between -6° and 56°C. When there are multiple battery charging devices and multiple batteries in a system, please ensure the maximum current flowing into and out of each battery is kept within the Maximum Continuous Charge Current and Maximum Continuous Discharge Current given in [Table 2 \(Connected PCE Programming Requirements\)](#).

Shutdown DC Voltage (No Load)	50V
Shutdown DC Voltage (0.5C)	48V
Recovery / Restart Voltage	52V
Continuous Charge Voltage	55.7V
Continuous Charge Transition	Battery is considered full after battery is absorbing less than 0.5% of maximum charge current after being held at specified charge voltage for 30 minutes minimum.
Float Voltage Cyclic (Short Term Float) (Example Solar Application)	55.7V
Float Voltage Standby (Long Term Float) (Example UPS Application)	55.2V
Charge Current	46A
Peukert Exponent	1.02
Shutdown SoC Recommended	20%
Calibration to 100%	Every 7 days or more frequent where possible. (Ensures cell balancing is performed and keeps external SoC counter more accurate)

Voltages are specified at the battery terminals. Refer to website for charger settings for specific inverters.

*Table 2 (Connected PCE Programming Requirements)*

#### 6.3.1. FULL CHARGE UPON FIRST INSTALLATION

Batteries are delivered and shipped in a partial state of charge. Prior to discharging the batteries, the entire rack should be fully charged to the float stage.

If the battery system (external to the battery) also has an integrated SoC (State of Charge) counter, the initial full charge may be needed to calibrate the counter to a known battery SoC (some SoC counters may take a few cycles to learn the SoC).



#### **IMPORTANT**

This initial full charge to 100% will allow the battery's BMS to perform Battery String Balancing to ensure all cells are at the same state before regular cycling. See [Section 6.3.2](#) for further details.

#### 6.3.2. BATTERY STRING BALANCING

It is essential that the battery is allowed to perform string balancing at least once every 7 days to improve the overall performance of the battery and to optimise the battery's longevity. String balancing allows the BMS to equalise the battery cells to limit apparent battery capacity slip and the process ensures the battery will charge correctly on subsequent charge cycles.

Battery string balancing is achieved by:

1. The battery terminal voltage being over 55.4V, and
2. The recommended charger settings being applied. See website for [Custom Charger Settings](#).



## IMPORTANT

If the battery's low voltage protection circuit has operated to protect the battery from excessive discharge, it is important that the battery is charged to 100% within 7 days. Leaving the battery in a discharged state can cause irreversible damage to the battery and reduce long term battery capacity.

### 6.3.3. PRIMARY CHARGING SOURCE

A primary charging source is the charging device used to charge the battery with up to 95% of the total charge energy of the battery and should be identified in the system and programmed to charge the batteries as outlined in [Table 2 \(Connected PCE Programming Requirements\)](#).

### 6.3.4. SECONDARY CHARGING SOURCE

A secondary charging source are charging devices typically delivering less than 20% of the total charge battery energy. Secondary charging sources must be set 0.2–0.5V less than the primary charging source.

### 6.3.5. PRIMARY CHARGING SOURCE WITH SECONDARY CHARGING SOURCE EXAMPLE

**Primary Charging Source** = Solar PV; will be used to supply 75% of the charging energy and will be programmed as per [Table 2 \(Connected PCE Programming Requirements\)](#).

**Secondary Charging Source** = Solar Charge Controllers; will be used to supply approximately 25% of the charging energy. The device must be set up to 0.5V less than the Continuous Charge Voltage specified in [Table 2 \(Connected PCE Programming Requirements\)](#) and if operated at the same time as the primary charge source must not exceed the specified Charge Current.

### 6.3.6. POWER CONVERSION EQUIPMENT (PCE) SETTINGS

Where PowerPlus Energy has released custom settings for specific Power Conversion Equipment (PCE), such settings take precedence over the settings provided in this document.

In the absence of custom settings, [Table 2 \(Connected PCE Programming Requirements\)](#) provides generic settings suitable for most PCE when using Eco4847P.

### 6.3.7. COMPATIBILITY WITH PWM CHARGER

The Eco4847P is not compatible with PWM chargers including solar, wind or micro hydro. Contact PowerPlus Energy for more information.

## 6.4. CALIBRATION TO 100%

Internal cell balancing of the battery happens during the end of the charging process. It is important for battery health to ensure battery capacity does not slip over time and batteries are charged to 100% at least once every 7 days as a minimum.

## 6.5. SOC (STATE OF CHARGE) DRIFT

SoC drift happens when the product that is calculating SoC builds up an accumulative error. This error is generally due to tolerance of components that measure voltage and current and algorithms used to calculate how full the battery is, incorrect settings used in PCE or higher consumption than normal. Most products will reset its accumulative error when the system gets to 100% SoC or float.

It is important a well-designed battery storage system reaches float or 100% as regularly as possible, preferably every 1 to 2 days to reset SoC drift, however, can be extended if required.

SoC drift can be tackled in many ways. See examples below.

1. Sufficient solar sized to charge batteries to float or 100% on the winter Solstice.
2. Backup source installed (grid or generator) to allow charging of batteries during extended bad weather or high load events.
3. Ascertain from PCE manufacturer the accuracy of the SoC calculator. If a higher more accurate shunt can be used with the PCE to monitor system SoC, then this should be considered.

## 7. TROUBLESHOOTING

This section is designed to help you identify and resolve common issues you may encounter while using our battery. For each issue, we have provided possible causes and suggested solutions. If you cannot resolve the issue or need further assistance, please do not hesitate to contact our Customer Support team

+61 (3) 8797 5557    support@powerplus-energy.com.au    Available Monday to Friday, 9 AM to 5 PM [AEDT]

During normal operation of the Eco4847P battery, whilst the DC Circuit Breaker is in the ON position, there will be a voltage present across the terminals of the battery.

However, when the operation of the battery goes outside its design limits, the BMS will enter an alert state. During this alert state, there may not be a voltage present across the terminals of the battery. If the BMS activates its alert state, once the fault is cleared, the battery may need external assistance to restart depending on the type of fault.

To recover from a fault condition, the user/installer will need to take the relevant remediation action listed in [Table 3 \(Eco4847P Status Codes\)](#).

No. of Flashes	LED Status	Action
2 Flashes	One or more cell-strings under-voltage	Use constant current charger to re-charge battery. Refer to <a href="#">Section 7.1.3</a>
3 Flashes	One or more cell-strings over-voltage	Apply load to discharge battery.
4 Flashes	Over-current whilst charging	Discharge battery with load over 55W per battery.
5 Flashes	Over-current whilst discharging	Remove load.
6 Flashes	Short-circuit across battery terminals OR High-level over-current whilst discharging	Remove short circuit. Assess load and capacity of battery to drive load, add additional battery modules.
7 Flashes	Cell-pack over-temperature whilst charging	Turn off charging devices until battery cools and resets.
8 Flashes	Cell-pack over-temperature whilst discharging	Turn off discharging devices until battery cools and resets.
9 Flashes	Cell-pack under-temperature whilst charging	Wait until the battery cell-pack warms up. Refer to <a href="#">Section 7.1.6</a>
10 Flashes	Cell-pack under-temperature whilst discharging	Wait until the battery cell-pack warms up. Refer to <a href="#">Section 7.1.6</a>
11 Flashes	BMS over-temperature	Remove load and allow battery to cool.
12 Flashes	BMS under-temperature	Warm the battery with external heating devices. Refer to <a href="#">Section 7.1.6</a>
13 Flashes	Cell-pack under-voltage	Use constant current charger to re-charge battery. Refer to <a href="#">Section 7.1.3</a>
14 Flashes	Cell-pack over-voltage	Apply a load to discharge battery.
15 or 16 Flashes	Cell-pack critically under-voltage	Contact PowerPlus Energy.

*Table 3 (Eco4847P Status Codes)*

## 7.1. UNDER VOLTAGE BATTERY RECOVERY

### 7.1.1. UNDER VOLTAGE SHUTDOWN

Indicated by 2 or 14 flashes on the status LED. Use an approved current limited battery charger. Contact PowerPlus Energy.

### 7.1.2. BMS THRESHOLD UNDER VOLTAGE SHUTDOWN

Under voltage shutdown occurs if the voltage in the battery reaches a designated LOW level. In the under-voltage shutdown state, the battery will not provide a DC voltage at its terminal (voltage will be <4V) until the system has been reset.

In the event of an under-voltage shutdown the battery will last up to 3 months before potentially reaching a **critical** under voltage shutdown, please see [Section 7.1.5](#). The battery will not deliver power to a load from its DC terminals until the battery module exceeds the under-voltage shutdown threshold.

### 7.1.3. UNDER VOLTAGE SHUTDOWN RECOVERY

This procedure is a guide and should be performed by suitably qualified person.

1. Shutdown system following your shutdown procedure.
2. Ensure all loads are switched off.
3. Turn off battery/s via DC circuit breaker and wait 30 seconds.
4. Turn on battery via DC circuit breaker.
5. Wait for battery Main Status LED to illuminate.
6. Connect and turn on site PCE.
7. If the PCE starts up, action a full charge cycle using an approved current limited battery charger.
8. If the battery fails turn on or remain on long enough to start a PCE charge, refer to [Section 7.1.5](#).

### 7.1.4. CRITICALLY UNDER VOLTAGE SHUTDOWN

Indicated by 15 or 16 flashes on the status LED. If a battery has been left unused for a long period without charge, it may become excessively self-discharged and enter a critically under voltage shutdown mode.

Also, if a battery has become damaged for some unexpected reason, it may also enter a critically under voltage shutdown mode to protect itself and the users.

Once critically under voltage shutdown occurs the battery can no longer be charged or discharged.

### 7.1.5. CRITICALLY UNDER VOLTAGE SHUTDOWN RECOVERY

Critically under voltage shutdown is not a user-serviceable fault.

Contact your installer or PowerPlus Energy.



#### NOTE

Your installer or PowerPlus Energy should be consulted if your battery will not activate.



### 7.1.6. EXTREME COLD

In some situations where the cell pack is exposed to extreme cold conditions for an extended period, the BMS will prevent charging (and discharging) to limit damage to the battery. Refer to [Section 4.4 \(Operating Temperature Range\)](#) for temperature limits of the battery.

Provided there is still some charge in the battery and the temperature is above the discharge low temperature threshold, discharging the battery may warm up the cells enough to allow the battery to take a charge.

Alternatively, the addition of a thermostatically controlled heat source (such as a cabinet heater or preferably a heating mat) may assist in preventing low temperature shutdown. For further assistance contact your installer or PowerPlus Energy.

## 8. MAINTENANCE

The Eco4847P is designed to require no regular maintenance from users. However, as part of your overall system maintenance, some checks can be carried out at least yearly.

- Check Status LED.
- Check battery DC Circuit Breaker by turning it off and on again.
- Check battery connections and cables for secure fitting or damage.
- Check for any obstruction placed around the battery or battery enclosure.
- Check for animals, insects or creatures nesting in or around the battery enclosure.
- Check for build-up of any foreign objects in or around the cabinet.
- Check all PCE settings are correct against the current published settings from the PowerPlus Energy website.

## 9. UPGRADING BATTERY CAPACITY

Additional batteries can be added to an existing Eco4847P installation later. It is not possible to mix different battery types and capacities to an existing battery rack. Therefore, all batteries in a rack must be of the same type, part number, and specification – unless advised by PowerPlus Energy.

Before adding one or more new batteries to the rack, this new battery voltage and the existing battery rack voltage must be within 0.2VDC of each other.

This may be achieved by using one of the following methods:

- By charging both the new battery and the existing battery to fully charged separately before combining them into the same battery system.
- Insert the new battery to a partially discharged battery bank ensuring the new battery and the battery bank are within 0.2V of each other. Charge banks up and maintain our recommended continuous charge voltage for up to 6 hours before floating or allowing load to be applied.

Remember to update all PCE charging current and battery capacities to reflect the new increased battery storage system capacity.

## 10. CAPACITY TESTING THE BATTERY

The battery capacity can be measured and verified by following the below test procedure. This should be performed using calibrated test equipment and performed by a suitably qualified person.

To determine the battery capacity, the below process should be conducted by a suitably qualified professional and performed at an ambient temperature of 25°C with the battery already at float:

- Discharge the battery at 0.5C until 48V.
- Charge the battery at the recommended continuous charge voltage and 0.5C rate and hold at that voltage until float is reached.
- Record the number of hours it takes to reach low voltage cut-off point.

The State of Health of the rated capacity can now be calculated as below and as a % of original capacity.

$$\left( \frac{(Ah * 0.5) * Discharge\ hrs}{Ah} \right) * 100$$

Ah = Amp Hour Capacity

0.5 = 0.5C constant load discharge

100 = Conversion to %

**Example:**

Eco4847P Ah Capacity = 92Ah

Battery time to discharge under test = 1.85hrs

$$= \left( \frac{(92 * 0.5) * 1.85}{92} \right) * 100$$

= 92.5%

It is recommended to repeat the above test two to three times and average the results.

## 11. COMPATIBLE GRID-CONNECT HYBRID INVERTERS

Visit the PowerPlus Energy website to access the latest list of compatible inverters.

## 12. END OF LIFE

When a PowerPlus Energy battery is removed from service it can be returned to PowerPlus Energy for recycling.

Due to the stability and longevity of LFP cylindrical cells, returned batteries will be refurbished and checked so they can be repurposed for low power applications and made available for community, education, and charity projects.

Any batteries not suitable for repurposing will be sent to a licensed recycling facility, where all ferrous and nonferrous metals are separated and then forwarded to our recycling partners.

## 13. WARRANTY

PowerPlus Energy will protect this product under warranty when it is installed as written in this manual and used as set out in the warranty documents. Any product not being used or installed as outlined will be in violation of the terms and will render the product void of any warranty.

PowerPlus Energy does not cover warranty or any liability for damages or defects caused or from the following:

- Incorrect storage or transportation.
- Incorrect installation and wiring.
- Installed not according to this manual.
- Incorrect operation.
- Inappropriate environmental conditions when operating the battery.
- Failure to follow safety requirements.
- Tampering of or opening the battery.
- Unauthorised repairs or modifications.
- External influences such as physical damage, over charging or electrical damage.
- Used outside of warranty terms and conditions.